

Standard Construction and Materials

- FRAME:** 18-GA. galvanized steel, channel or flanged type.
- BLADE:** 18-GA. galvanized steel. Blades approximately 2½" on centers.
- SCREEN:** (When indicated)
½" sq. mesh, 19-GA. galvanized steel (.041").
- CONSTRUCTION:** Riveted and/or welded for maximum service.

Options

- Frames and Blades of other gauges
- Other materials - Stainless steel, Copper, Aluminum, etc.
- Finishes - Enamels, Epoxies, etc.
- Screens - Insect screen ⅜ aluminum mesh,
 - or- ½" flattened aluminum, .051",
 - or- ¼" sq. mesh, 18-GA galvanized steel, .047",
 - or- ½" sq. mesh, 18-GA stainless steel, .047",
- Others available.

Notes

1. Nominal deductions will be made to the opening size given.
2. Approximate shipping weight is 5.5 lbs./sq.ft.

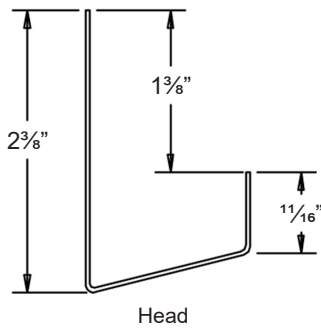
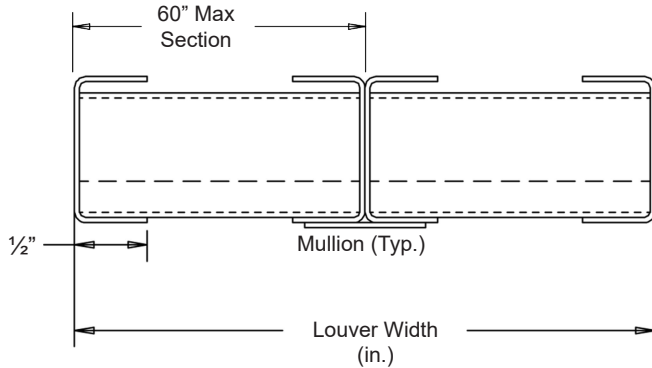
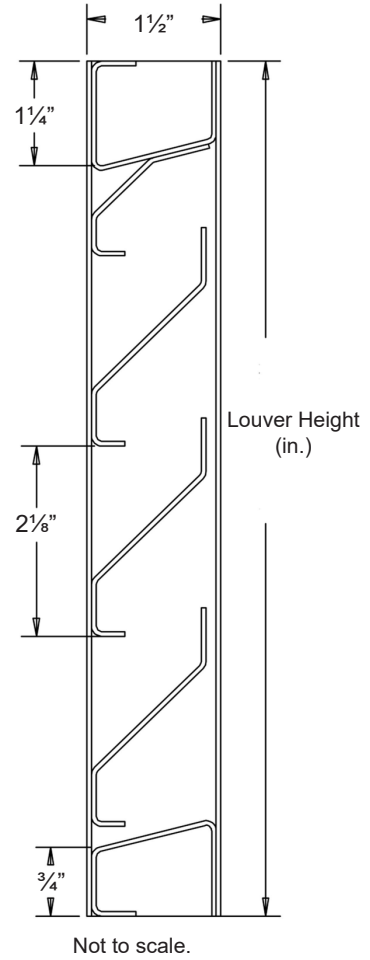

Flange Frame Available

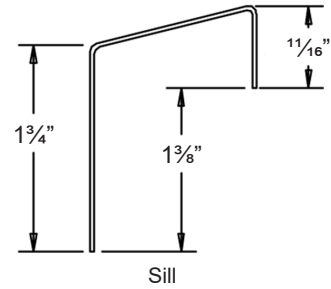
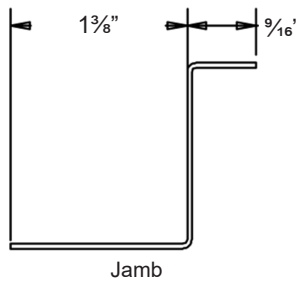

<u>Item #</u>	<u>Qty</u>	<u>Width</u>	<u>Height</u>	<u>Width</u>	<u>Height</u>	<u>Mullion</u>	<u>Type</u>	<u>Location</u>		
		<u>Opening Size</u>		<u>Louver Size</u>			<u>Screens</u>		<u>Union Made</u>	
<u>Arch. / Eng.:</u>						<u>EDR:</u>		<u>ECN:</u>	<u>Job:</u>	
<u>Contractor:</u>										
<u>Project:</u>						<u>Date:</u>		<u>DWN:</u>	<u>DWG:</u>	

In the interest of product development, Cesco Products reserves the right to make changes without notice.



450 Riverside Dr • Wyalusing PA, 18853
 Phone: 570-746-1888 • Fax: 570-746-9286
 www.cescoproducts.com